



# FLEXI-WALL



## MP-Series Acoustic Movable Partitions



The key to cost-effective space planning



## INTRODUCTION

Flexible space planning is the key to cost-effective building design. To meet the needs, **FLEXI-WALL** has developed a range of 'Flatwall' partition systems that make the most of an internal space to multi-purpose buildings - such as hotels, schools, exhibition and conference areas, restaurants, community buildings, leisure and sports centres - or where space is at a premium.

**FLEXI-WALL** MP - series movable partition systems are practical, durable, and presentable and it offers flexible, effective sound reduction with Sound Transmission Class (STC) ranging from 35 dB to 52 dB. The systems are custom-made and all partition panels are based on a strong and rigid steel frame that is built to last.

**FLEXI-WALL** MP - series movable partitions are supplied in bare finish thus it is versatile to meet your interior designing needs. PVC, laminates, painting, timber veneers and fabrics are some of the commonly used finishes that can be applied on the panels. The single or double leaf pass doors can be fitted within the panels. Accessories including pin and chalkboard are available as optional items.

Since our partitions are used by people in the working, social or meeting environment, **FLEXI-WALL** has commissioned an inspection on a typical construction against criteria defined in DIN standards 1050, 1055, 52210, 31000. The consequent test result was issued on 08.06.84 and was confirmed that the products meet those technical standards.

## WHERE TO USE FLEXI-WALL PARTITIONS

- convention halls
- banquet halls
- meeting rooms / lecture halls
- training and conference areas
- auditoriums
- classrooms
- audio-visual areas
- multi-purpose rooms
- cafeterias
- fellowship halls
- stage areas, including drama and music rooms
- any place where reliable sound control plus flexible use of space is needed

## FEATURES

### ACOUSTIC PERFORMANCE

The high quality particle boards on each side of the panel are attached to the frame by small, sturdy, spaced brackets thus achieving maximum separation possible between the boards and the frame which contributes greatly to the high attenuation performance achieved in test of a three (3) panel partitions.

The acoustic value was tested to the requirements of ASTM E-90-75. The Sound Transmission Class (STC) value ranges from 32 - 52 dB depending on the models.

### DURABILITY

Robust, steel framed construction ensures panel strength, rigidity and stability. The high density 15mm thick material boards give additional strength and dimensional stability. This ensures a product that gives consistently high return of trouble free operation in use with minimum maintenance.

### PASS DOOR

The single or double leaf pass doors can be fitted within each individual panel where it can be served as an entrance.

- Minimum height of a panel is 2.4m. The construction for panels and doors is of strong rectangle tube sections welded into the basic frame shape. Door hinges are heavy duty type incorporated thrust bearings. Panels and doors have retractable seals, standard hardware and heavy duty lock.
- The "L" type construction combine adjacent panels each having a door hinged to the single leg element so that the doors open as a double door facility.
- A door panel is alternatively hinged to jamb post at either extreme of the opening. Since the panel is the same height as other panels, account must be taken of partition height.

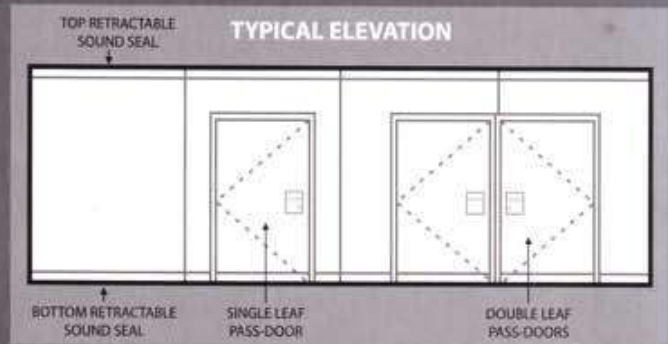

### AESTHETICS/ FINISHES

Once extended into place, **FLEXI-WALL** operable walls form a clean, uninterrupted surface. Their edges create only a fine line separating the panels and the operable walls are supplied in bare finish. The particle boards mounted on each side of the panel can support and accommodate any decorative finishes required or specified, inclusive of PVC, laminates, painting, timber veneers and fabrics depending on the interior designing needs.

### FLEXIBILITY

The availability of many systems present a selection of configurations to fit any applications. In addition, the systems can be equipped with 'T' junction or 'X' junction that fulfills every specifications. Optional, right angle turn system allows panels to be reversed easily, permitting unique storage layouts that facilitate panel use in multiple locations.

### SERVICES

The company supports its products with technical advice, drawings, site surveys, installation, after sales service and maintenance as required, requested or necessary. All these are carried out by our well-trained and professional personnel.

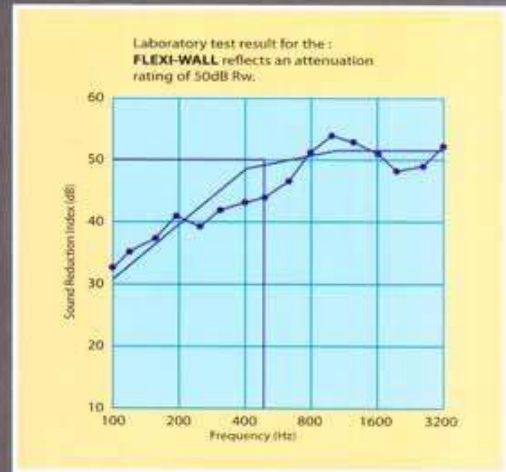

TRACK AND TROLLEY SYSTEM

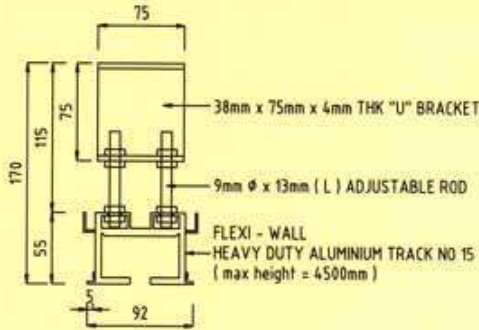

A. CENTRE STACK WITH ONE CENTRE TROLLEY CARRIAGE USING ALUMINIUM TRACK NO 15

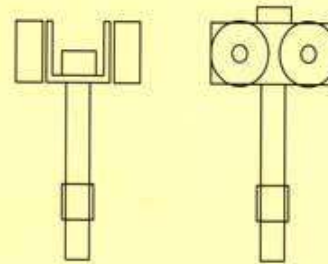

FLEXI - WALL  
FOUR (4) WHEELS TROLLEY WITH BOLT CARRIAGE

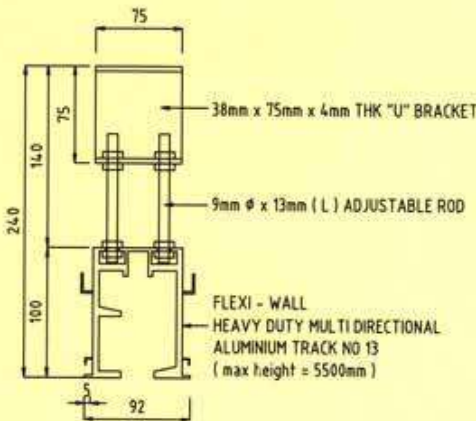

B. SITE OR REMOTE STACK WITH RIGHT ANGLE TURN THROUGH X, T OR L FUNCTION WITH TWO TROLLEYS PER PANEL SUSPENSION USING ALUMINIUM TRACK NO.13 OR NO.16



FLEXI - WALL  
TWO (2) WHEELS MULTI-DIRECTIONAL TROLLEY WITH BOLT ( NO 13 )

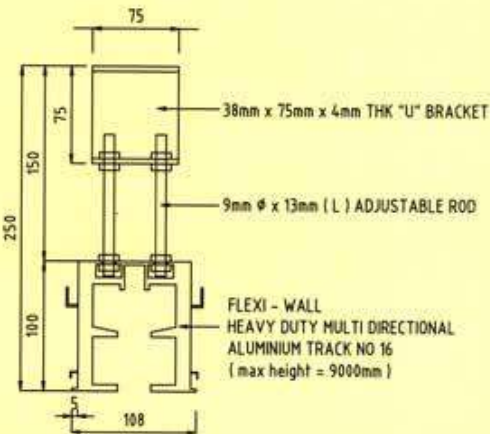

C. SITE STACK WITH RIGHT ANGLE T OR L FUNCTION WITH TWO TROLLEYS PER PANEL SUSPENSION

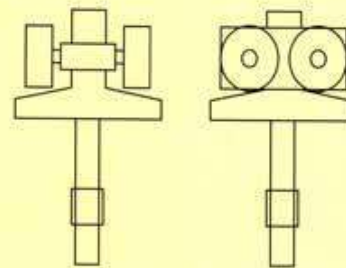

FLEXI - WALL  
FOUR (4) WHEELS MULTI-DIRECTIONAL TROLLEY WITH BOLT ( NO 16 )

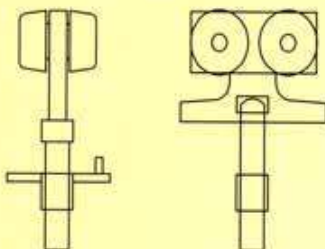

FLEXI - WALL  
FOUR (4) WHEELS MULTI-DIRECTIONAL TROLLEY WITH BOLT ( NO 100 )

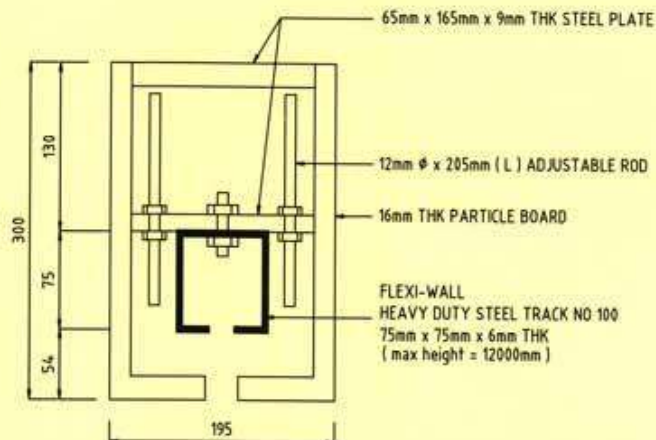

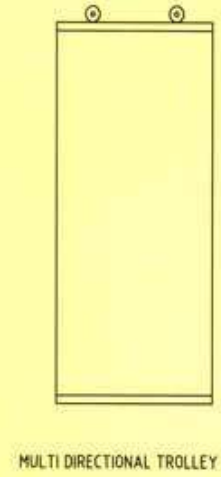
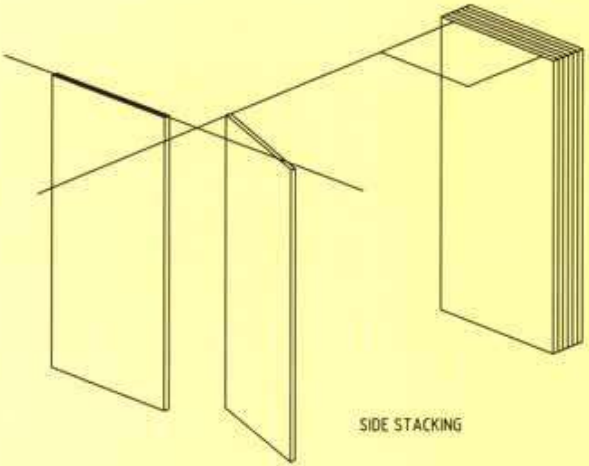
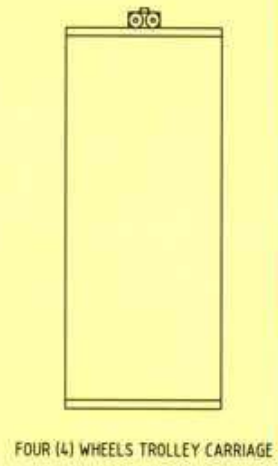
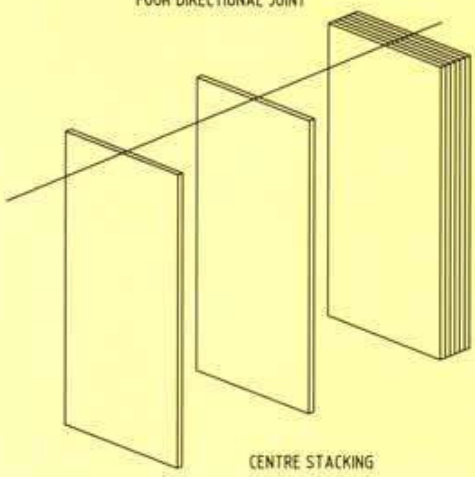
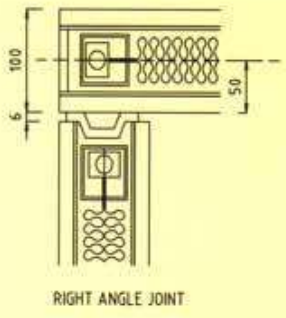
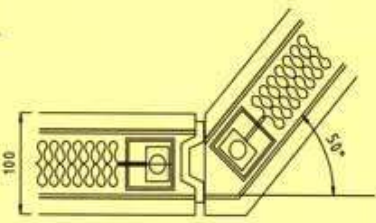
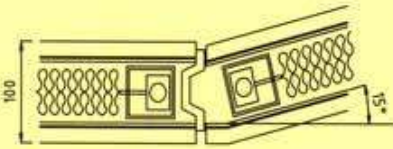
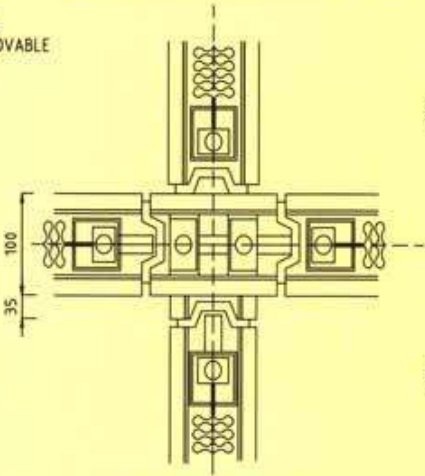
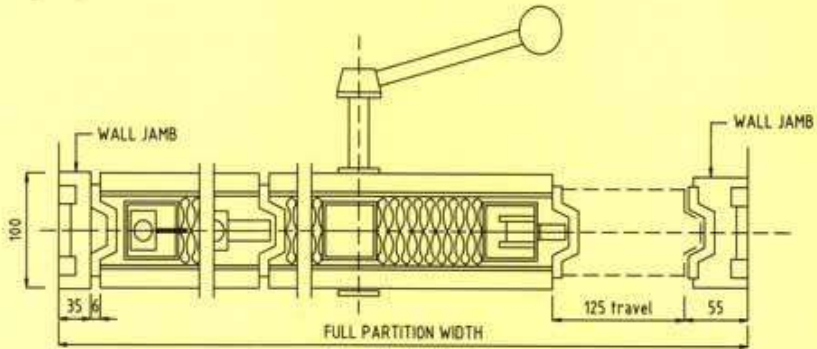
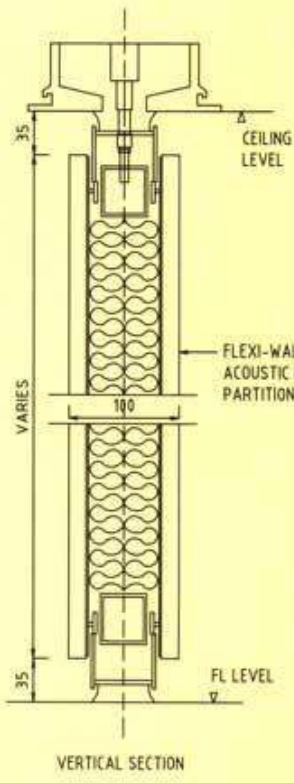



## FLEXI-WALL MP - SERIES SPECIFICATIONS

Nominal panel thickness is 100mm.

Panel approximate weight is 55 kg/m<sup>2</sup>.

Shadow line gap between panel in situ 6mm.

Pendent bolt from trolley stressed for 24000N.

Particle boards to be of minimum floor grade quality (650 density) and balanced to suit finish on front face. For centre stacking facility, panel shall incorporate one (1) central trolley carriage. It is recommended that track boxing soffit (20mm) be below ceiling surface. For a side or remote stacking facility there will be two trolleys to carry each panel.

### ASTRAGALS

Each panel is individually operated with silver anodized extruded aluminum tongue and groove elements fitted to the height of the panel and is incorporated with extruded P.V.C seals. The inter-panel engagements enhance the 'wall' stability and contribute to the sound attenuation performance.

### INTERMEDIATE PANEL FRAME

Each panel is made of 50x50x3mm CR Channel on each side and 40x40x4mm steel box section top and bottom welded together to make a strong rigid frame. The trolley support incorporates pendent bolts of 2.0 kg tensile each.

### OPERABLE PANELS

To achieve final closure of partition or to slide partition wall to stay away, at least one panel in the partitions has a moving nose element with a traveling distance of 125mm, which is operated manually with a socket handle. The operable panel for closure achieves an adjustable lateral thrust of 0 - 3000N.

### RETRACTABLE SEALS

Black anodised extruded aluminum channels house substantial P.V.C seals and are fitted top and bottom of panel for its width. Ratchet operated and spring loaded, when expanded the seals stabilize the panel as a single element and greatly contribute to collective stability. The springs accommodate reasonable building tolerances and deflection. Retracted, they remove any friction contact in the opening and permit easy movement. When fully retracted into the panel, a clearance of 35mm is created between top and bottom of panel with existing F.F.L and soffit.



DISTRIBUTOR